

CASE STUDY

Intel® Ethernet Converged Network Adapter X520-DA2

Manufacturing
Data Center Optimization

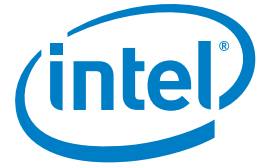

Cutting Costs and Complexity

German manufacturer doubles LAN and storage network performance with Intel® Ethernet 10 Gigabit Converged Network Adapters



"We have reduced our network complexity by focusing on one technology, Ethernet, meaning we do not need to maintain a SAN fabric. We have higher performance to handle large file transfers and storage expansion."

*- Jürgen Sonntag,
IT Manager,
Hansa Metallwerke AG*

Hansa Metallwerke AG, a renowned German manufacturer, wanted a more flexible and cost-effective infrastructure to support its global business operations. Under the leadership of IT Manager Jürgen Sonntag, Hansa has centralized all IT services in Stuttgart and developed a state-of-the-art data center to support the consolidated services.

A key decision in designing the data center was to upgrade and standardize both LAN and storage communications on Intel® Ethernet 10 Gigabit Converged Network Adapters. Now, network costs are down, performance has doubled, IT is more efficient, and Hansa has more flexibility to respond to business changes.

CHALLENGE

Business growth placed greater demands on Hansa's server, network, and storage infrastructure, and increased the need for robust data-recovery (DR) capabilities. Hansa's IT leaders wanted reliable, high-capacity infrastructure that could ensure business continuity, reduce costs, and scale to meet future needs.

SOLUTION

Hansa deployed a next-generation data center with a second, fully mirrored center for DR. The company upgraded and standardized its LAN and storage networks on the Intel Ethernet Converged Network Adapter X520-DA2 and adopted the Internet SCSI (iSCSI) protocol for storage networks. Servers are powered by the Intel® Xeon® processor 5600 series and also run StorMagic's SvSAN* to provide an economical storage virtual network solution.

BUSINESS BENEFIT

The new network with Intel Ethernet 10 Gigabit Converged Network Adapters doubled the performance of Hansa's previous quad-port Ethernet adapters. Hansa saved more than 50 percent by avoiding the purchase of traditional storage controllers, and reduced costs for Storage Area Network (SAN) cards and switches by 30 percent. Operations costs are lower since IT now supports just one network technology.

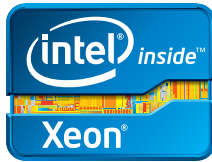

“Everything works together smoothly. We would not have been able to achieve the cost savings of the StorMagic SvSAN without the high performance of the Intel host systems and the high data throughput of the Intel Ethernet 10 Gigabit adapters with iSCSI between the StorMagic host systems and the RAID systems.”

– Jürgen Sonntag,
IT Manager,
Hansa Metallwerke AG

Next-Generation Data Center for the Next Stage of Growth

Even in challenging economic conditions, smart companies can find a way to succeed. Hansa Metallwerke is a great example. Headquartered in Stuttgart, Hansa manufactures and distributes bathroom fittings that combine design elegance, German quality manufacturing, and water and energy conservation features. Hansa has a presence in 50 nations and is an aggressive innovator, launching 13 new products in a 14-month period during 2010–2011. Hansa’s business strategies yielded 9.1-percent revenue growth in 2010 over the previous year, along with triple the earnings before interest, taxes, depreciation, and amortization (EBITDA).

Hansa’s growth has placed greater demands on its data center. Engineers and designers make heavier use of applications such as CATIA* and generate larger files as they develop increasingly sophisticated products. Increased use of virtualization with more virtual machines (VMs) per processor led to higher loads on the company’s previous Fibre Channel SAN and Ethernet LANs.

To support the growing business, Hansa’s IT leaders decided to modernize the company’s infrastructure and centralize its data centers in Stuttgart. They chose Intel® server and Ethernet technologies to help them increase performance and throughput, optimize data center operations, reduce costs, and deliver computing capacity as needed.

Standardizing on Intel® Ethernet 10 Gigabit Converged Network Adapters

Hansa’s data center modernization team worked with Computer Haug, an Intel Platinum Partner, together with the independent service provider Stainczyk & Partner for design, selection, and implementation. They decided on Intel® technologies for servers, networks, and storage control, selecting the products for

their high performance, energy efficiency, reliability, cost-effectiveness, and a record of value-added innovation.

For network architects, a key decision was to upgrade and standardize storage and LAN communications on Intel Ethernet Converged Network Adapters X520-DA2. Reflecting the maturity of the iSCSI protocol on 10 gigabit Ethernet (10GbE), Hansa moved storage traffic from a Fibre Channel SAN to iSCSI on the Intel Ethernet Converged Network Adapters. Standardizing on 10GbE enabled Hansa to improve performance while reducing network complexity, simplifying configuration and management, and eliminating the need to maintain expertise on multiple network technologies.

Hansa uses VMware ESX* to virtualize its server workloads with Citrix XenApp* (HDX*) and XenDesktop* (HDX 3D) to deliver virtual desktops to client systems. The company provides 100 megabit connectivity to the clients.

Value-Added Advantages with Intel Technologies

In considering 10GbE adapters, Hansa identified several advantages provided by the Intel Ethernet Converged Network Adapter X520 family. “Intel’s Ethernet adapters are well known for their compatibility and reliability,” says Jürgen Sonntag. “They support almost all known operating systems. They offer a very high data throughput and stability with affordable pricing. By using the Intel Ethernet Converged Network Adapters in the servers, along with Intel® processors, motherboards, and chipsets, we are able to create a very stable, high-performance environment that is also very cost effective.” The Intel® adapters provided a twofold increase in data throughput over Hansa’s quad-port Ethernet adapters.

The Intel Ethernet Converged Network Adapter X520 family incorporates a range of technical capabilities to increase performance and flexibility. The Intel

family supports both iSCSI and Fibre Channel over Ethernet (FCoE). The adapters also provide the choice of optical short and long-range transceivers or direct-attach copper cables. Capabilities such as Virtual Machine Device Queues (VMDq) work with Intel Xeon processor-based servers to enhance performance in virtualized environments (see sidebar).

Optimizing Servers, Storage, and the End-User Experience

Hansa employs virtualization with the Intel Xeon processor 5600 series-based servers to simplify its IT environment, reduce costs, and increase performance, resource utilization, and availability. One new data center has six Intel® Server

VMDQ: ENHANCING VIRTUALIZED TRAFFIC MANAGEMENT

Virtual Machine Device Queues (VMDq), a component of Intel® Virtualization Technology for Connectivity, optimizes the processing of virtual machine (VM) data traffic to improve network performance and CPU utilization.

As the number of VMs on a server increases, so does the amount and complexity of traffic. VMDq manages the VMs' data traffic efficiently to reduce the I/O bottleneck in the system:

- **Throughput.** Eases throughput limitations by providing an alternative to hypervisor-based packet sorting
- **Scalability.** Creates parallel data I/O paths in the network I/O silicon, avoiding performance degradation as the number of VMs increases
- **Capacity.** Liberates CPU cycles otherwise consumed by packet sorting, making them available to applications

These advances promise to increase server-consolidation ratios, adding to the cost savings associated with virtualization solutions.

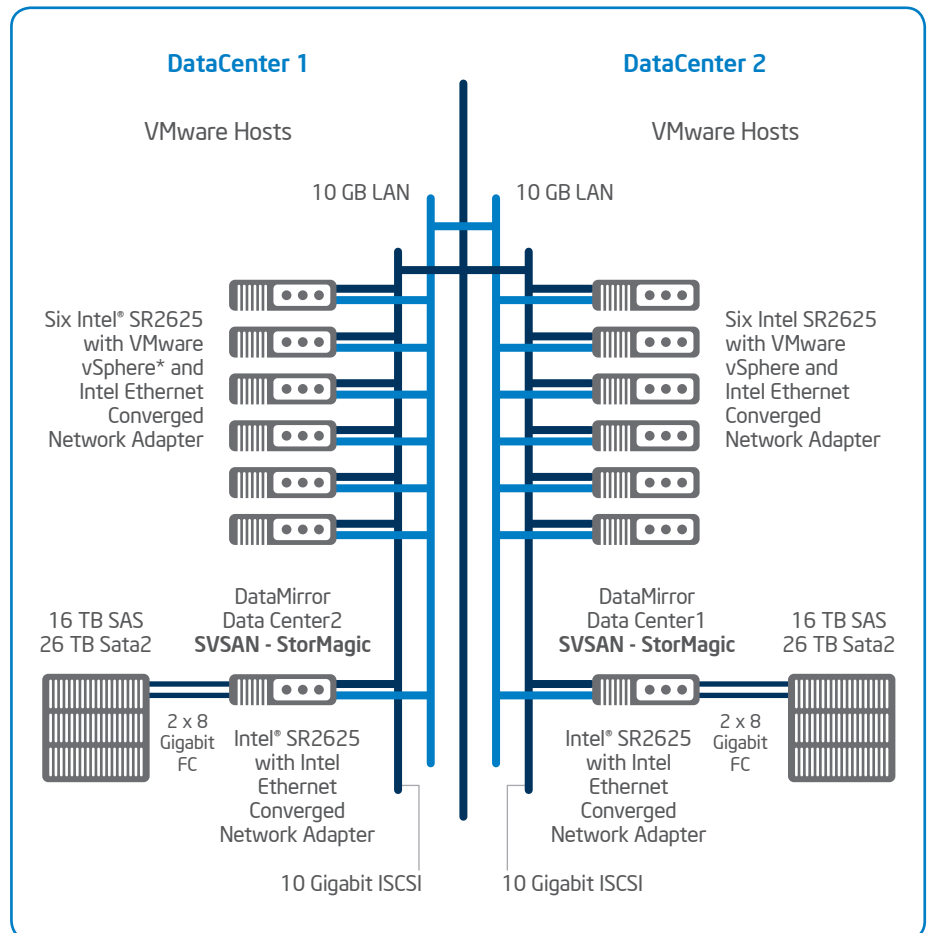

Systems SR2625, each with two six-core Intel Xeon processors 5600 series and 96 gigabytes (GB) of RAM. Servers are used for file, web, application, and database servers, supporting 48 applications and four databases in a VMware High Availability (HA) cluster. The environment is mirrored across the two data centers.

Hansa is also using the Intel Xeon processor 5600 series to enhance its storage environment. Two additional Intel Server Systems SR2625 run StorMagic SvSAN, providing a fast, simple, and affordable RAID control solution. StorMagic SvSAN offloads the mirroring and high availability functions from hard disk drive subsystems and uses Intel servers to perform those functions. Hansa estimates that the solution has helped them avoid the purchase of traditional

storage controllers, which would have cost over 50 percent more, and has reduced its costs for SAN cards and switches by 30 percent. The system accesses 42 terabytes (TB) of Infortrend storage: 16 TB of serial-attached SCSI (SAS) and 26 TB of Serial ATA (SATA).

The speed of the Intel Ethernet Converged Network Adapters X520-DA2 and the iSCSI interface between the virtualized servers and the StorMagic platforms contributes directly to higher performance and productivity for end users. Hansa's research and development simulation processes can produce more than 100 GB of output, and the Intel Ethernet 10 Gigabit Converged Network Adapters transfer those files to the Product Lifecycle Management system without slowing the network. "Everything works together



smoothly," Sonntag says. "We would not have been able to achieve the cost savings of the StorMagic SvSAN without the high performance of the Intel host systems and the high data throughput of the Intel Ethernet 10 Gigabit adapters with iSCSI between the StorMagic host systems and the RAID systems."

The solution also helps deliver a responsive experience to users on their virtual desktops. "In the case of a large Select statement in a database query, the short-term load between the Citrix server and the database increases sharply," explains Sonntag. "With the Intel Ethernet 10 Gigabit Converged Network Adapters, this is no problem. This is also the case when a production user is moving

a foundry simulation to the viewer—the 10 gigabit connection between the Citrix server and the file server handles this very smoothly."

Delivering Business Value

Hansa has achieved a significant performance increase through the interplay between application, database, file server, Citrix server, and hard disk systems over networks based on Intel Ethernet 10 Gigabit Converged Network Adapters. Hansa's IT department is delivering strong business value through its new data center, its virtualized environment, and its use of Intel Ethernet and server technologies. By choosing Intel technologies for networks, servers,

and RAID controllers, Hansa increases consistency throughout the environment, leading to greater IT efficiency and reliability. By upgrading and standardizing its LAN and storage networks on Intel Ethernet Converged Network Adapters X520-DA2, Hansa reduces costs and complexity in its IT environment and provides the performance and throughput the company needs in order to continue its growth. The company enjoys the benefits of agile infrastructure and a robust DR solution. Business units can more easily deploy new capabilities that help them bring innovative products to market quickly, and IT has generated cost savings that can fund further innovation and contribute to the bottom line.

About Intel® Ethernet

Intel is the industry leader in Ethernet controllers and adapters with a broad product portfolio and 30 years of experience delivering connectivity that enterprises depend on.

www.intel.com/go/ethernet

SOLUTION PROVIDED BY:

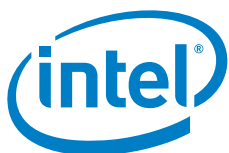

Intel appreciates the contributions of Klaus Heinzlmann of Computer Haug and Joachim Stainczyk of Stainczyk & Partner, who provided information for this case study.

Intel® Virtualization Technology requires a computer system with an enabled Intel® processor, BIOS, and virtual machine monitor (VMM). Functionality, performance, or other benefits will vary depending on hardware and software configurations. Software applications may not be compatible with all operating systems. Consult your system manufacturer. For more information, visit www.intel.com/go/virtualization.

Copyright © 2012 Intel Corporation. All rights reserved. Intel, the Intel logo, and Xeon are trademarks of Intel Corporation in the U.S. and other countries.

*Other names and brands may be claimed as the property of others.

0412/BY/MESH/PDF

327253-001US